

### Description

The ST0361D2 is a bi-directional TVS diode, utilizing leading monolithic silicon technology to provide fast response time, very low capacitance and low ESD clamping voltage, making this device an ideal solution for protecting voltage sensitive data and power line. The ST0361D2 complies with the IEC 61000-4-2 (ESD) with  $\pm 20\text{kV}$  air and  $\pm 15\text{kV}$  contact discharge. It is assembled into an ultra-small  $0.6 \times 0.3 \times 0.3\text{mm}$  lead-free DFN package. The small size and very low capacitance make ST0361D2 an ideal choice to protect cell phone, digital cameras, audio players, data interface and many other portable applications.

### Mechanical Characteristics

- ◆ Package: DFN0603-2 ( $0.6 \times 0.3 \times 0.3\text{mm}$ )
- ◆ Lead Finish: NiPdAu
- ◆ Case Material: "Green" Molding Compound.
- ◆ Moisture Sensitivity: Level 3 per J-STD-020
- ◆ Terminal Connections: See Diagram Below
- ◆ Marking Information: See Below

### Features

- ◆ Ultra small package:  $0.6 \times 0.3 \times 0.3\text{mm}$
- ◆ Protects one data or power line
- ◆ Very low capacitance: 16pF typical
- ◆ Ultra low leakage: nA level
- ◆ Operating voltage: 3.3V
- ◆ Low clamping voltage
- ◆ 2-pin leadless package
- ◆ Complies with following standards:
  - IEC 61000-4-2 (ESD) immunity test  
Air discharge:  $\pm 20\text{kV}$   
Contact discharge:  $\pm 15\text{kV}$
  - IEC61000-4-4 (EFT) 40A (5/50ns)
  - IEC61000-4-5 (Lightning) 8A (8/20 $\mu\text{s}$ )
- ◆ RoHS Compliant

### Applications

- ◆ Cellular Handsets and Accessories
- ◆ Notebooks and Handhelds
- ◆ Portable Instrumentation
- ◆ Digital Cameras
- ◆ Peripherals
- ◆ Audio Players
- ◆ Keypads, Side Keys, USB, LCD Displays

### Dimensions and PIN Configuration

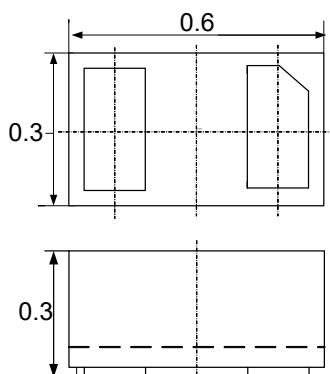

Package Dimensions (mm)

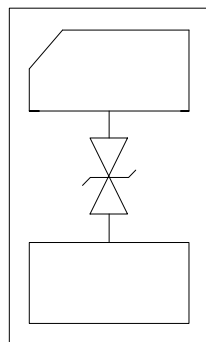

Circuit and Pin Schematic

### Ordering Information

Part Number	Packaging	Reel Size
ST0361D2	10000/Tape & Reel	7 inch

**Absolute Maximum Ratings (TA=25°C unless otherwise specified)**

Parameter	Symbol	Value	Unit
ESD per IEC 61000-4-2 (Air) ESD per IEC 61000-4-2 (Contact)	VESD	±20 ±15	kV
Operating Temperature Range	TJ	-55 to +125	°C
Storage Temperature Range	Tstg	-55 to +150	°C

**Electrical Characteristics (TA=25°C unless otherwise specified)**

Parameter	Symbol	Min	Typ	Max	Unit	Test Condition
Reverse Working Voltage	VRWM			3.3	V	
Breakdown Voltage	VBR	4.3			V	IT = 1mA
Reverse Leakage Current	IR			0.2	uA	VRWM = 5V
Clamping Voltage	VC			7	V	IPP = 1A (8 x 20µs pulse)
Clamping Voltage	VC			10	V	IPP = 8A (8 x 20µs pulse)
Junction Capacitance	CJ		16		pF	VR = 0V, f = 1MHz

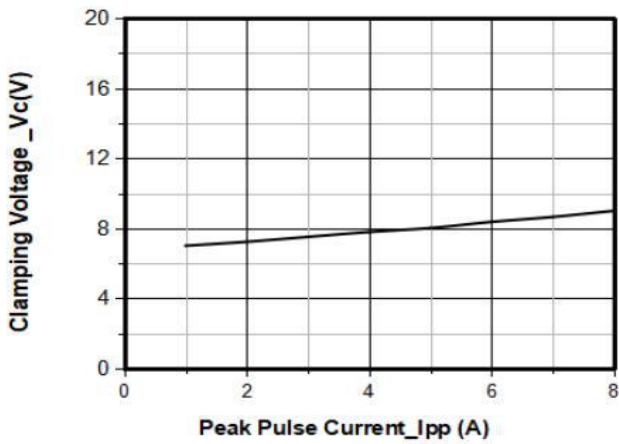
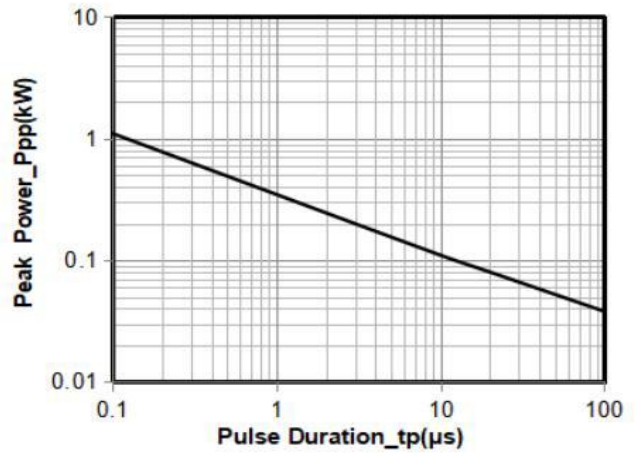
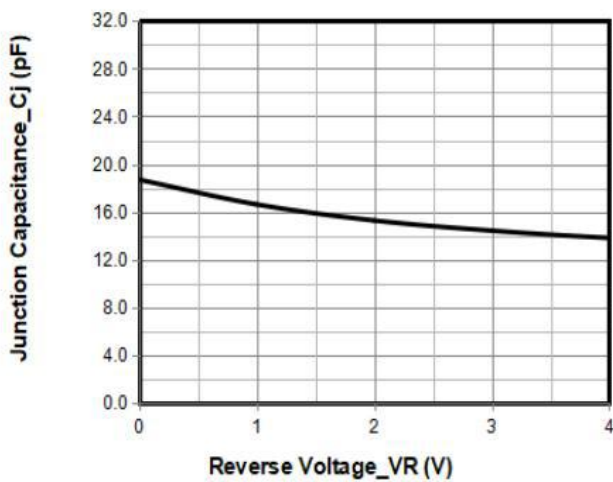
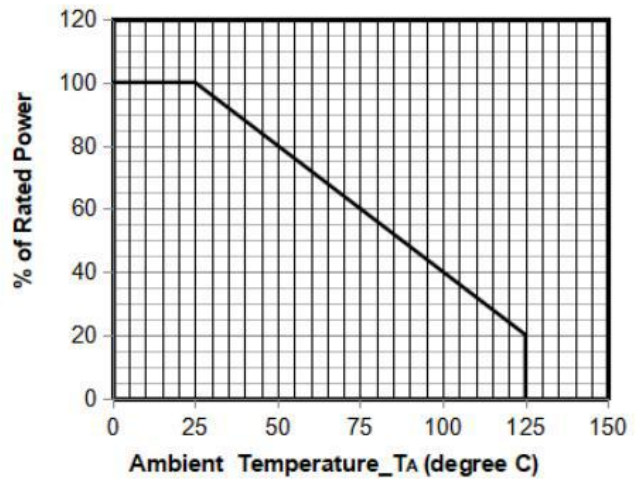
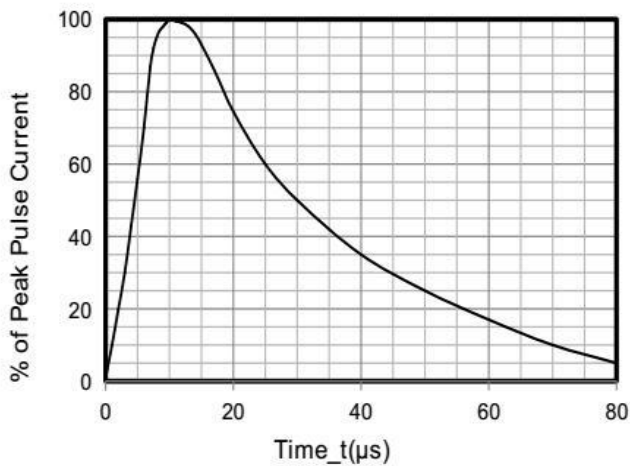
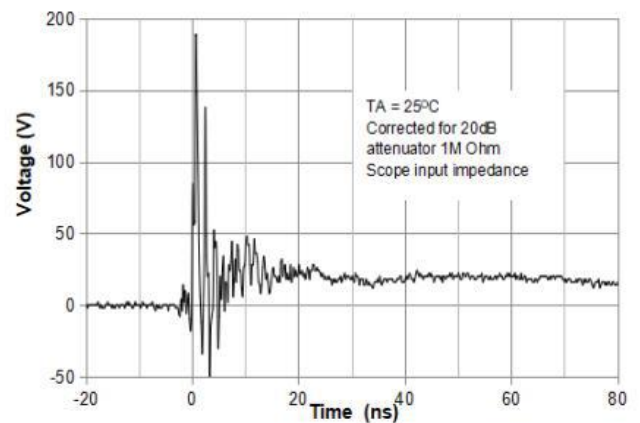
**Typical Performance Characteristics (TA=25°C unless otherwise specified)**

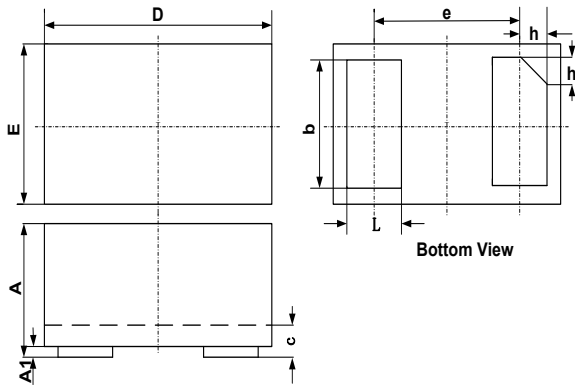
**Junction Capacitance vs. Reverse Voltage**

**Peak Pulse Power vs. Pulse Time**

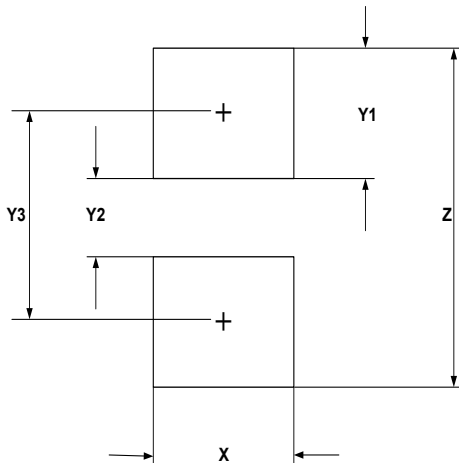
**Clamping Voltage vs. Peak Pulse Current**

**Power Derating Curve**

**8 X 20μs Pulse Waveform**

**ESD Clamping Voltage**
**8 kV Contact per IEC61000-4-2**

**DFN0603-2 Package Outline Drawing**

SYM	DIMENSIONS		
	MILLIMETERS		
	MIN	NOM	MAX
A	0.230		0.330
A1	0.000	0.020	0.050
b	0.215	0.245	0.275
c	0.120	0.150	0.180
D	0.550	0.600	0.650
e	0.355 BSC		
E	0.250	0.300	0.350
L	0.160	0.190	0.220
h	0.079 BSC		

**Suggested Land Pattern**

SYM	DIMENSIONS	
	MILLIMETERS	INCHES
X	0.30	0.012
Y1	0.25	0.010
Y2	0.15	0.006
Y3	0.40	0.016
Z	0.65	0.026

**Contact Information**

Sursemi Technologies, Inc.

396 Arbor Court, Simi Valley, CA 93065

Phone: (805) 402-0326 Email: sales@sursemi.com