

Description

The ST0561D2 is a bi-directional TVS diode, utilizing leading monolithic silicon technology to provide fast response time and low ESD clamping voltage, making this device an ideal solution for protecting voltage sensitive data and power line. The ST0561D2 complies with the IEC 61000-4-2 (ESD) standard with $\pm 15\text{kV}$ air and $\pm 8\text{kV}$ contact discharge. It is assembled into an ultra-small 0.6x0.3x0.3mm lead-free DFN package. The ultra small size and high ESD surge protection make ST0561D2 an ideal choice to replace 0201 size multilayer varistors (MLVs) and protect cell phone, digital cameras, audio players and many other portable applications.

Features

- ◆ Ultra small package: 0.6x0.3x0.3mm
- ◆ Very low capacitance
- ◆ Protects one data or power line
- ◆ Ultra low leakage: nA level
- ◆ Low operating voltage: 5V
- ◆ Low clamping voltage
- ◆ 2-pin leadless package
- ◆ Complies with following standards:
 - IEC 61000-4-2 (ESD) immunity test
Air discharge: $\pm 15\text{kV}$
Contact discharge: $\pm 8\text{kV}$
 - IEC61000-4-4 (EFT) 40A (5/50ns)
 - IEC61000-4-5 (Lightning) 4A (8/20 μs)
- ◆ RoHS Compliant

Mechanical Characteristics

- ◆ Package: DFN0603-2 (0.6x0.3x0.3mm)
- ◆ Lead Finish: NiPdAu
- ◆ Case Material: “Green” Molding Compound.
- ◆ UL Flammability Classification Rating 94V-0
- ◆ Moisture Sensitivity: Level 3 per J-STD-020
- ◆ Terminal Connections: See Diagram Below
- ◆ Marking Information: See Below

Applications

- ◆ Cellular Handsets and Accessories
- ◆ Personal Digital Assistants
- ◆ Notebooks and Handhelds
- ◆ Portable Instrumentation
- ◆ Digital Cameras
- ◆ Peripherals
- ◆ Audio Players
- ◆ Keypads, Side Keys, USB 2.0, LCD Displays

Schematic and PIN Configuration

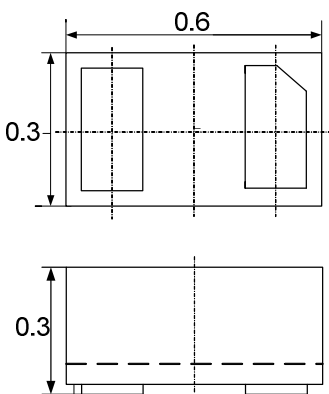

Package Dimensions

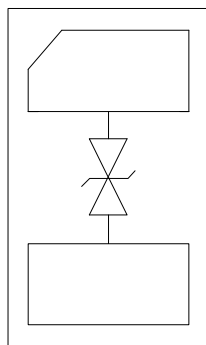

Circuit and Pin Schematic

Ordering Information

Part Number	Packaging	Reel Size
ST0561D2	10000/Tape & Reel	7 inch

Absolute Maximum Ratings (TA=25°C unless otherwise specified)

Parameter	Symbol	Value	Unit
Peak Pulse Power (8/20μs)	Ppk	60	W
Peak Pulse Current (8/20μs)	Ipp	4	A
ESD per IEC 61000-4-2 (Air)	VESD	±15	kV
ESD per IEC 61000-4-2 (Contact)		±8	
Operating Temperature Range	TJ	-55 to +125	°C
Storage Temperature Range	Tstg	-55 to +150	°C

Electrical Characteristics (TA=25°C unless otherwise specified)

Parameter	Symbol	Min	Typ	Max	Unit	Test Condition
Reverse Working Voltage	VRWM			5	V	
Breakdown Voltage	VBR	6	8	9	V	IT = 1mA
Reverse Leakage Current	IR			200	nA	VRWM = 5V
Clamping Voltage	VC			10	V	I _{PP} = 1A (8 x 20μs pulse)
Clamping Voltage	VC			15	V	I _{PP} = 4A (8 x 20μs pulse)
Junction Capacitance	CJ		12		pF	VR = 0V, f = 1MHz

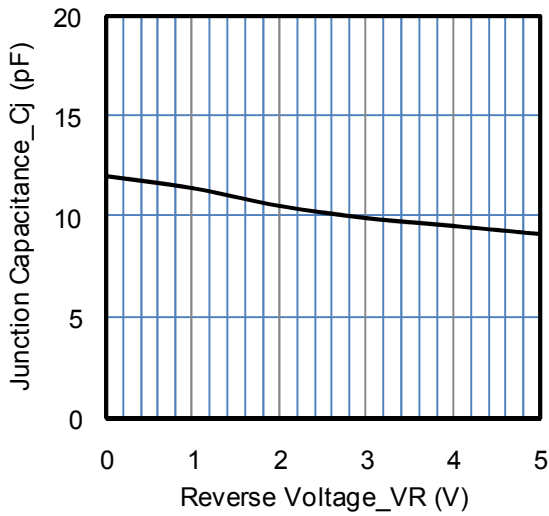
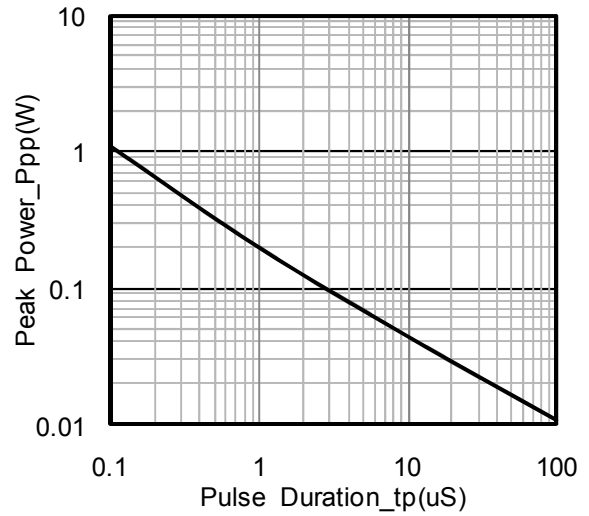
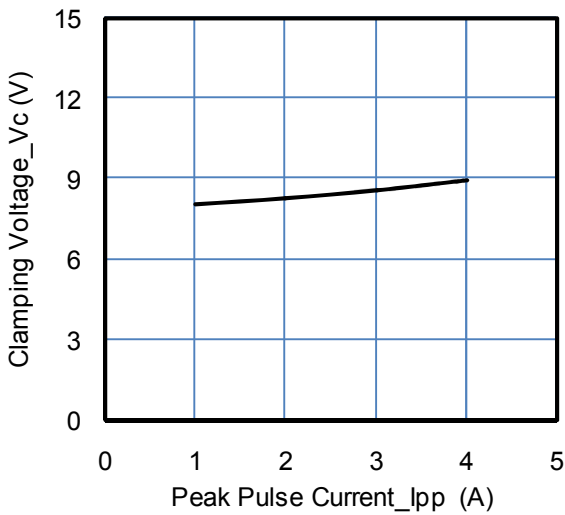
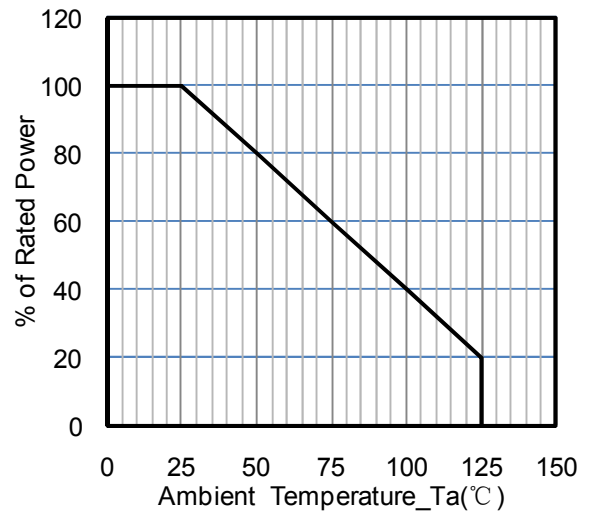
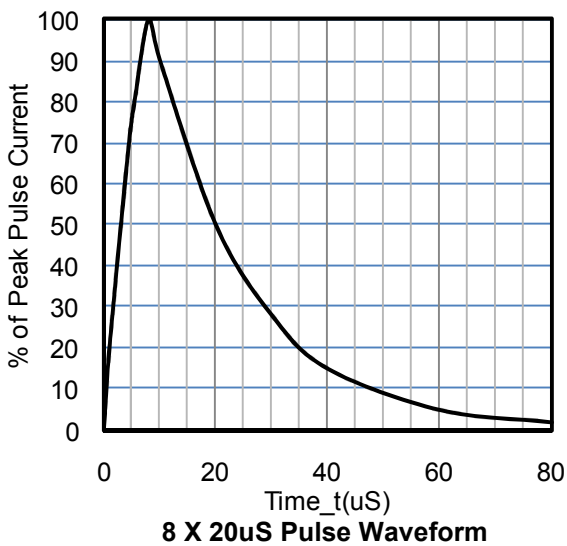
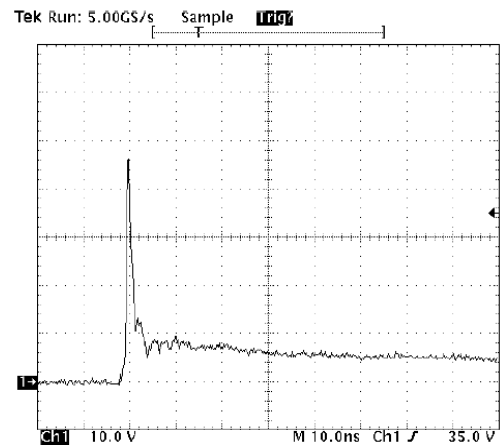
Typical Performance Characteristics (TA=25°C unless otherwise specified)

Junction Capacitance vs. Reverse Voltage

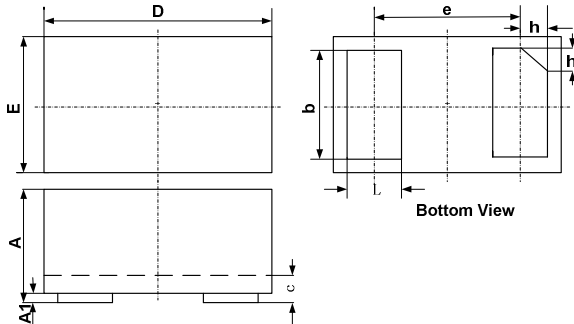
Peak Pulse Power vs. Pulse Time

Clamping Voltage vs. Peak Pulse Current

Power Derating Curve

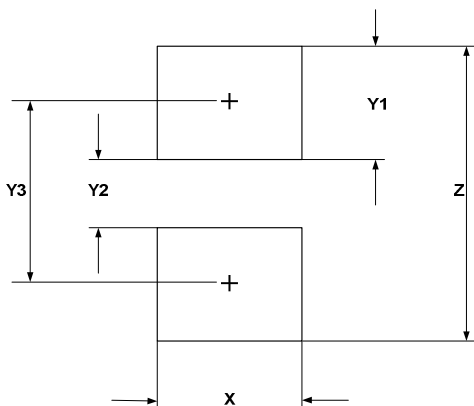
8 X 20uS Pulse Waveform

**ESD Clamping Voltage
8 kV Contact per IEC61000-4-2**

DFN0603-2 Package Outline Drawing



SYM	DIMENSIONS		
	MILLIMETERS		
	MIN	NOM	MAX
A	0.230		0.330
A1	0.000	0.020	0.050
b	0.215	0.245	0.275
c	0.120	0.150	0.180
D	0.550	0.600	0.650
e	0.355 BSC		
E	0.250	0.300	0.350
L	0.160	0.190	0.220
h	0.079 BSC		

Suggested Land Pattern



SYM	DIMENSIONS	
	MILLIMETERS	INCHES
X	0.30	0.012
Y1	0.25	0.010
Y2	0.15	0.006
Y3	0.40	0.016
Z	0.65	0.026

Contact Information

Sursemi Company Limited

396 Arbor Court, Simi Valley, CA 93065

Phone: (805) 402-0326 Email: sales@sursemi.com